

# THE ULTIMATE HEATED SOAK TANK SYSTEM

Your Solution to Dirty Kitchen Equipment



CLEANING POWER



LABOR SAVING



LOWER ENERGY



SPACE SAVER



WATER SAVER



# WHAT IS THE FOG TANK?

The FOG Tank® is a fully insulated and thermostatically controlled stainless steel soak tank that safely and easily removes fat, oil, grease, and carbon build-up from your metal cookware and kitchen equipment, including aluminum. FOG is an acronym for Fat, Oil, and Grease.

# HOW DOES IT WORK?

The secret to the success of the FOG Tank is our safe and proprietary Tiger Carbon Remover Powder®. The powder is an environmentally safe cleaning agent that is non-caustic, non-toxic, fully biodegradable, and aluminum safe. Items removed from the tank are fully sanitized and bacteria-free.

## BEFORE & AFTER



[www.fogtank.ca](http://www.fogtank.ca)  
(858) 566 - 6212

# 5 EASY STEPS

TO CLEAN AND SHINY EQUIPMENT

## STEP 1

Fill the FOG Tank with (preferably hot) water to the 'Fill Line' marked on the inside, plug the tank into an electrical outlet, and switch ON.



## STEP 2

Slowly add the Tiger Carbon Remover Powder.



## STEP 3

Load the tank with your dirty pots, pans, vent hood filters, etc, using the 'lifting basket' that is housed inside the FOG Tank.



## STEP 4

Close the lid, leaving the items in the tank to soak, and walk away!



## STEP 5

Remove the items from the tank, then simply rinse off any loose or softened carbon fragments.





## INDUSTRIES WE SERVE

### RESTAURANTS

The FOG Tank's non-caustic, non-toxic, biodegradable, & food-safe Tiger Carbon Remover Powder efficiently and safely cleans your equipment.

"...We have valued having the Fog Tank at the Oceanaire for the past 10 years. As we have guests that are well-coming into our kitchen and enjoy watching our line cooks at work, having pots, pans and exhaust hood that appear almost new and in excellent hygienic condition is an impressive attribute. Thank you again for years of excellent service and a product that has paid for itself over and over again."

Oceanaire Seafood Room - Philip Shayne, General Manager

### HOTELS & CASINOS

Our superior stand-and-soak cleaning system provides flexibility to hectic hotel and casino kitchens, allowing staff to focus on creating quality cuisine and providing top-notch service.

"The FOG Tank is a great investment for any company because it will bring back to life the luster and sheen of the old items rather than anticipating replacements or purchases for those items. It is easy to clean, operate and maintain."

Flamingo Hotel & Casino - Christophe Doumergue, Executive Chef

### BAKERIES

The FOG Tank is available in multiple sizes to accommodate large quantities of pans, bread straps and even single and double racks.

"The FOG Tank is easy to clean and maintain. Employee training is minimal. I would recommend the FOG Tank to any food establishment and Bakery."

Caesars Palace Las Vegas - Patrick Aranda, Executive Steward

### HOSPITALS

The Fog Tank's Tiger Carbon Remover Powder sanitizes optimally and eliminates the bacteria from cookware and metal kitchen equipment to maintain the clean and sanitary environment that is so crucial in the healthcare industry.

"The service has been excellent, and we have been impressed by the level of back-up and the efficient delivery of chemicals and service. Unquestionably the FOG Tank does an excellent job, saves us money and makes our lives much easier. We highly recommend the system."

Orange County Hospital - Phil Martin, Facilities Manager

### SCHOOLS

The Fog Tank helps educational institutions maintain kitchens that meet HACCP standards while keeping overhead low.

"We strive to a level much higher than the standard health code. The FOG Tank allows us to keep a level of clean in our commercial kitchen that we could not reach or afford the old fashioned way."

L.A. School District - Mary DaSilva - Operations Manager

### OTHER INDUSTRIES WE SERVE

- Caterers
- Filter-Cleaners
- Cruise Ships
- Vent Hood Cleaners
- Government Agencies
- Entertainment Centers



## THE BENEFITS OF FOG TANK



### EFFORTLESS CLEANING

TIGER CARBON REMOVER POWDER® EFFICIENTLY AND SAFELY CLEANS YOUR EQUIPMENT WITH LITTLE TO NO SCRUBBING.



### SPACE SAVING

THE FOG TANK USES UP TO 60% LESS SPACE THAN A 3-COMPARTMENT SINK AND FITS UNDER THE COUNTER.



### LABOR SAVINGS

THE FOG TANK ELIMINATES HOURS SPENT SCRUBBING WHICH CAN REDUCE STEWARDING DEPARTMENT HOURS BY 3 HOURS PER DAY OR MORE.



### LOWER ENERGY BILLS

THE FOG TANK CAN SAVE A SINGLE RESTAURANT LOCATION OVER \$3,800 CAD PER YEAR IN ENERGY COSTS.



### LESS WATER USAGE

YOU CAN SAVE OVER 1,287,040 LITRES OF WATER PER YEAR USING THE FOG TANK.

# TECHNICAL SPECIFICATIONS

MINI

25 Gal.

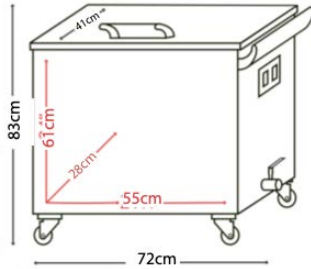

MINI	95 Litres	
POWER	OUTLET	CAPACITY
VOLTS: 120V AMPS: 8.33A HEATER: 1000W	15 AMPS NEMA 5-15R 	3-5 SHEET PANS 6 HOOD FILTERS*

STANDARD

40 Gal.

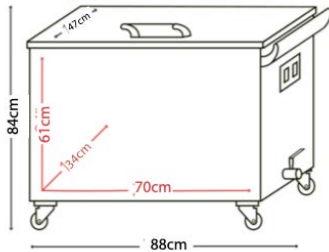

STANDARD	150 Litres	
POWER	OUTLET	CAPACITY
VOLTS: 120V AMPS: 8.33A HEATER: 1000W	15 AMPS NEMA 5-15R 	24 SHEET PANS 6 HOOD FILTERS*

MEDIUM

80 Gal.

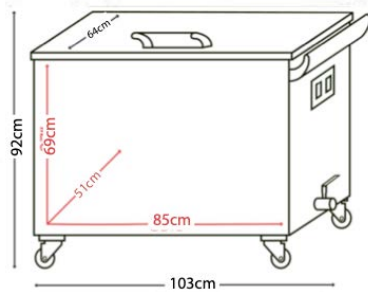

MEDIUM	300 Litres	
POWER	OUTLET	CAPACITY
VOLTS: 120V AMPS: 12.5A HEATER: 1500W	20 AMPS NEMA 5-20R 	50 SHEET PANS 20 HOOD FILTERS*

LARGE

120 Gal.

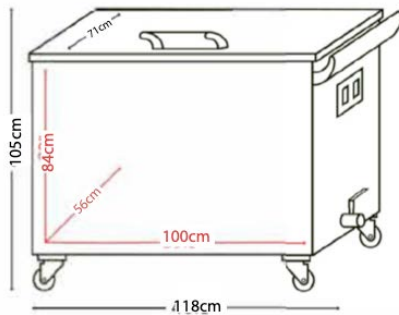

LARGE	454 Litres	
POWER	OUTLET	CAPACITY
VOLTS: 240V AMPS: 12.5A HEATER1: 1500W HEATER2: 1500W	20 AMPS NEMA 6-20R 	100+ SHEET PANS 28 HOOD FILTERS*

LP-LARGE

126 Gal.

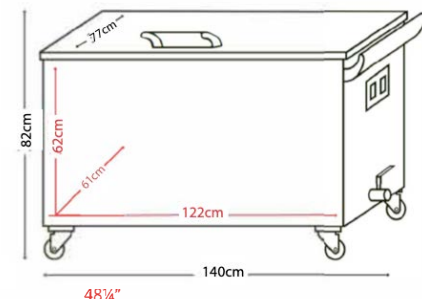

LP-LARGE	477 Litres	
POWER	OUTLET	CAPACITY
VOLTS: 240V AMPS: 12.5A HEATER1: 1500W HEATER2: 1500W	20 AMPS NEMA 6-20R 	100+ SHEET PANS 36 HOOD FILTERS*

\*Hood Filter Std size 51cmx51cmx3.5cm